

S2255BE/S2755BE

NARROW BI-ENERGY ROUGH TERRAIN SCISSOR LIFTS



- Narrow compact bi-energy rough terrain scissor lifts
- Suitable for interior and exterior use
- Non-marking high grip tyres
- Roll-out deck extension for extra reach
- Ideal for outdoor work in confined spaces

snorkelTM
www.snorkellifts.com

NARROW BI-ENERGY ROUGH TERRAIN SCISSOR LIFTS

S2255BE/ S2755BE

DIMENSIONS	S2255BE	S2755BE
Max. working height	8.5m	10.1m
Max. platform height (A)	6.5m	8.1m
Platform size (stowed)	1.4m x 2.73m	1.4m x 2.73m
Platform size (extended)	1.4m x 3.93m	1.4m x 3.93m
Extension deck length	1.2m	1.2m
Overall width (B)	1.45m	1.45m
Overall length (C)	3.3m	3.3m
Stowed height (D)	2.35m	2.5m
Min. height (guardrails folded)	2.0m	2.13m
Ground clearance	260mm	260mm

PERFORMANCE	S2255BE	S2755BE
Platform capacity (SWL)	420kg	300kg
Max. drive height	6.5m	7.7m
Max. wind speed	12.5m/s	12.5m/s
Max. drive speed (stowed)	5.2km/h	5.2km/h
Max. drive speed (elevated)	0.66km/h	0.5km/h
Raise/lower time	26/30 sec	26/30 sec
Gradeability (on diesel)	35%	35%
Max. outrigger levelling, front to rear	6°	6°
Max. outrigger levelling, side to side	10°	10°
Inside turning radius	2.5m	2.5m
Outside turning radius	4.75m	4.75m
Exit/entry angle	20°	20°
Tyres	0.58m x 0.22m - 12 non-marking	
Controls	proportional joystick	
Drive system	4-wheel drive	

POWER	S2255BE	S2755BE
Power source	Kubota diesel engine & 24V DC batteries	

WEIGHT	S2255BE	S2755BE
Weight	2,780kg	3,100kg

TURNING RADIUS

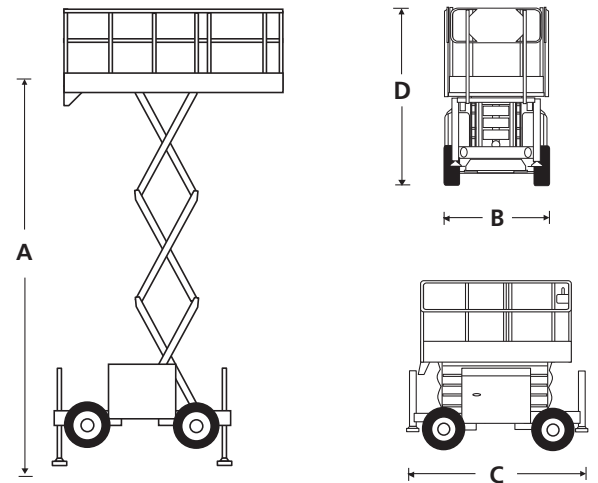
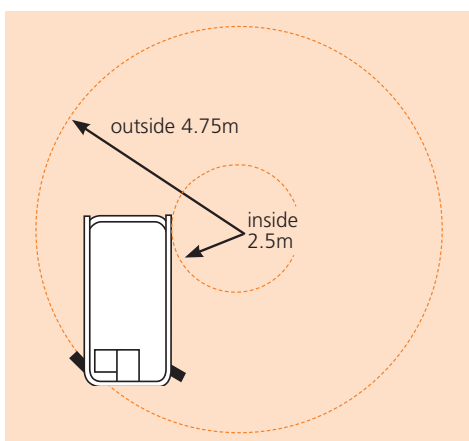

STANDARD FEATURES

- DC & diesel power - for indoor & outdoor work
- 4-wheel drive
- 4 hydraulic outriggers with automatic levelling
- Roll-out deck extension
- Proportional controls
- Non-marking tyres
- Power line to platform
- Drive motion alarm
- Descent alarm
- Manual lowering valve
- Flashing amber light
- Dual lanyard attachment points
- Oscillating axle
- Hour meter & on-board diagnostics display
- 2 year parts & labour, 5 year structural warranty
- CE approved

OPTIONS

- Special paint colours
- Nylon spreader pads (set of 4)
- Environmental hydraulic oil
- Cold weather package
- Snorkel OnSite™ telematics

snorkel www.snorkellifts.com

Vigo Centre, Birtley Road,
Washington, Tyne & Wear,
NE38 9DA, U.K.

t: +44 (0) 845 1550 057
e: sales.emea@snorkellifts.com